

GS

Zanurzeniowa pompa do ścieków z młynkiem

Temperatura cieczy: 0°C do 40°C
 Zakres mocy: 1.5 HP / 1.1 kW
 pH: 6 do 8
 Obroty: 2900/3450rpm
 Zabezpieczenie: IP68
 Max. zanurzenie: 8M

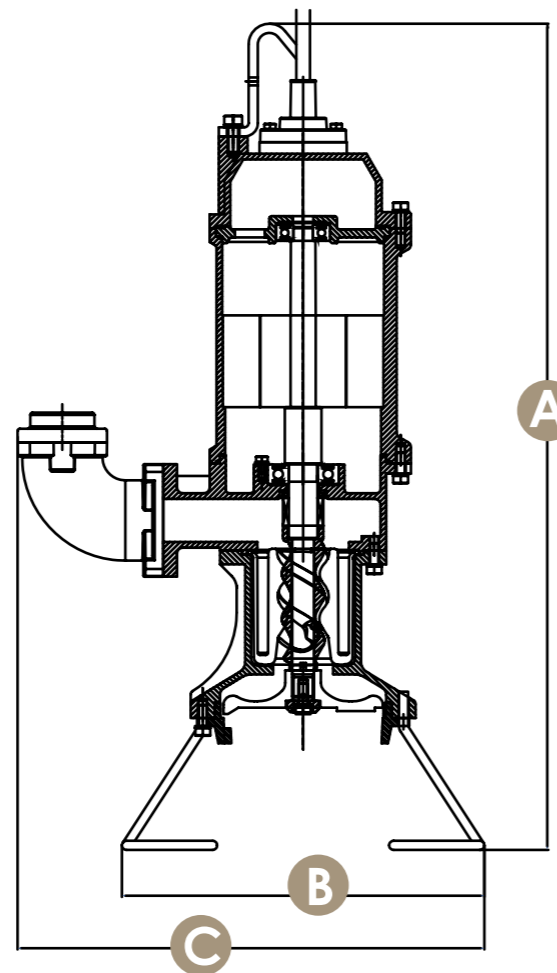

Wymiary Jednostka:mm

Model	A	B	C
GS-15	720	316	407

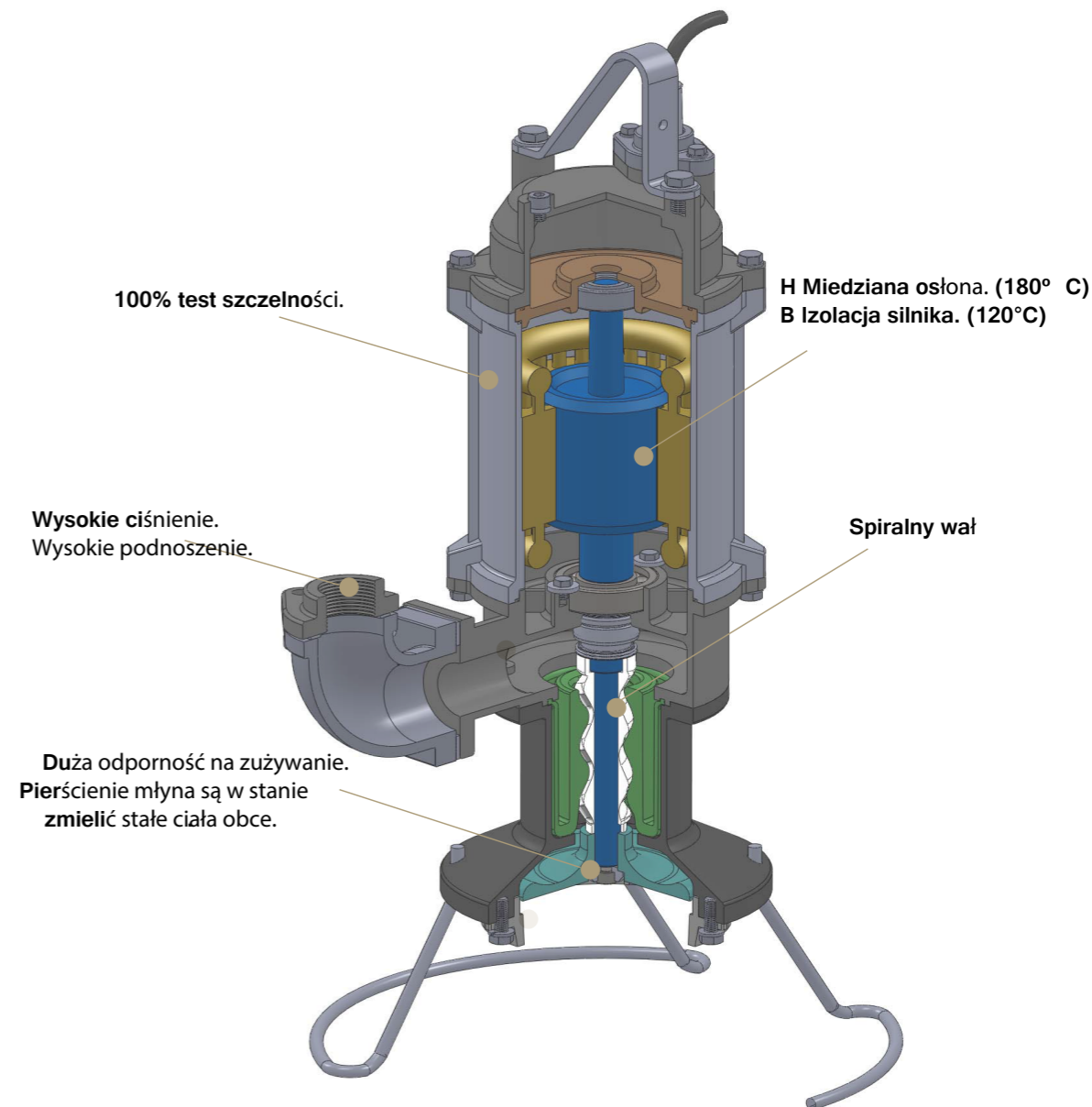
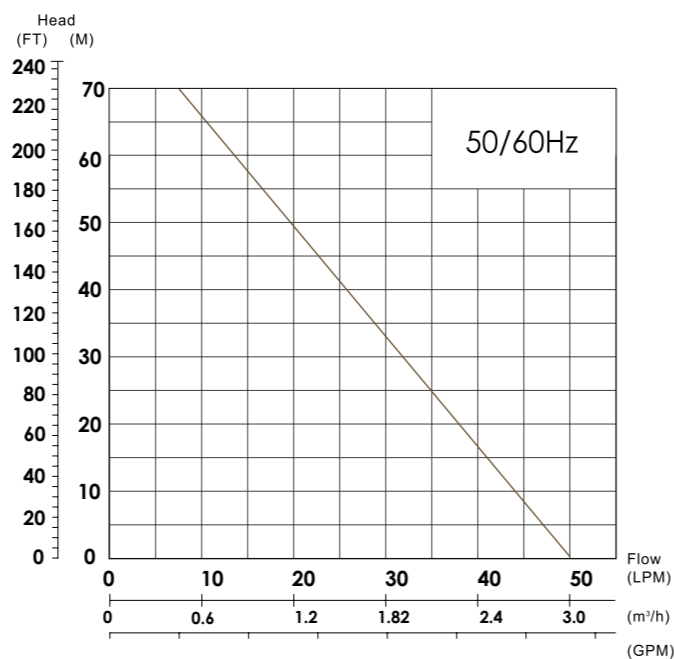

2" króciec



1 1/4" króciec



Konstrukcja młynka i wirnika

Specyfikacje

Model No.	Wyjście		Wyjście Max	Punkty pracy					Wymiary	Waga		
	HP	kW		mm	inch	przepl.(l/min)	10M	20M			30M	40M
GS-15	1.5	1.1	32	1-1/4	50	45	37	32	25	20	407x316x720	40